

锂离子电池规格书

Specification for Lithium-ion Rechargeable Cell

电池型号: 32140FS

Cell Type: 32140FS

Document No	CBNJ-PS-AA	Effective date	2022-6-13
Edition	A/02	Pages	11
Approved		Checked	Designed
陈红雨	曹广飞	邵义	姬鑫

Contents 目录

1. Preface 前言
2. Description 说明
3. Cell Size 电池尺寸
4. Construction 电池结构
5. Parameters 电池参数
 - 5.1. Summary 概要
 - 5.2. Charging Parameters 充电参数
 - 5.3. Discharge Parameters 放电参数
 - 5.4. Pulse Parameters 脉冲参数
6. Electrical Performance 电性能
7. Safety Performance 安全性能
8. Test Method 测试方法
 - 8.1. Standard Test Conditions 标准测试条件
 - 8.2. Standard Charge and Discharge Method 标准充放电制式
 - 8.3. Electrical Performance Test 电性能测试
 - 8.4. Safety Performance Test 安全性能测试
9. Packaging and Shipment 包装出货
 - 9.1. Packaging 包装
 - 9.2. Shipment 出货
10. Warranty 质量保证
11. Precautions and Safety Instructions 安全守则
 - 11.1. Standard cell Precautions 电池防范措施
 - 11.2. Cell Operation Instructions 电池使用说明
12. Consultation 技术咨询
13. Requirements for Safety Assurance 安全保证要求

1. Preface 前言

This Product Specification describes the technique requirements, test procedures and precaution notes of cylindrical type Lithium-ion Rechargeable cell to be supplied to customer by NANJING CBAK ENERGY TECHNOLOGY COMPANY LIMITED.

本标准规定了由南京中比新能源科技有限公司生产的锂离子电池的技术要求、测试方法和注意事项。

2. Description 说明

2.1. Product 产品: Lithium-ion Rechargeable cell 可充电锂离子电池

2.2. Model (Type) 电池型号: 32140FS

2.3. Designation 名称:

32	140	F	S
①	②	③	④

①: Indicates the diameter of cell 代表电池直径

②: Indicates the overall height of cell 代表电池高度

③: Indicates the property of the cell 代表电池特性

The letter "F" defines LiFePO₄ series cathode

"F"代表以 LiFePO₄ 为正极材料体系

④: Indicates the property of the cell 代表电池特性

The letter "S" defines steel can cell

"S"代表钢壳电池

3. Cell Size 电池尺寸

For details, please refer to Figure A. Remark: contain PET cover

对于电池尺寸的详细资讯, 请参阅图 A。备注: 包含热缩套

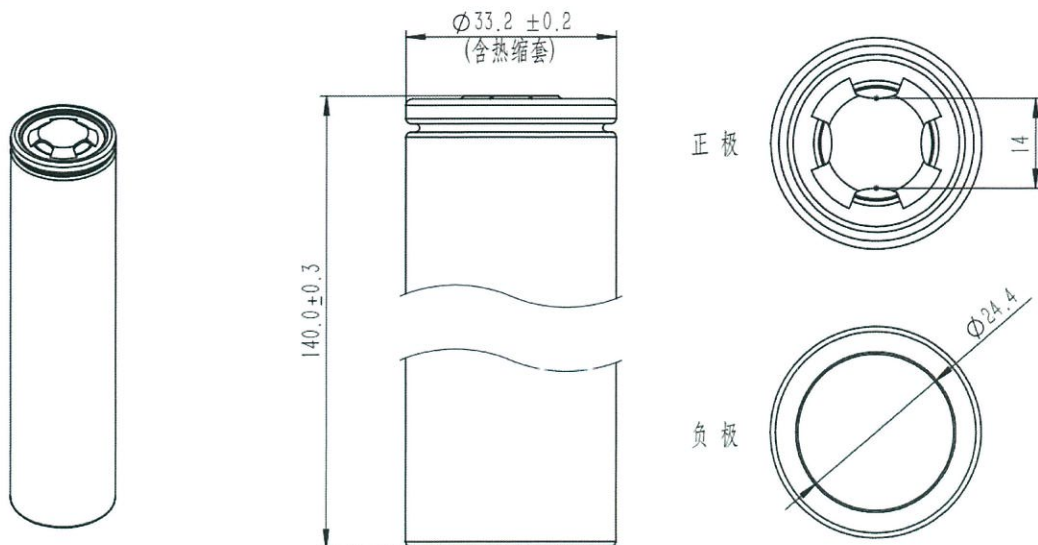

Figure A (图 A)

4. Construction 电池结构

A cell is made of cathode, anode, separator, steel can and cap, etc.

电池由正极、负极、隔膜、钢壳和盖帽等组成。

5. Parameters 电池参数

5.1. Summary 概要

Project 项目		Specification 规格	Condition 条件
Nominal Capacity 标称容量		15Ah	25±2°C, 0.5C/0.5C
Minimum Capacity 最小容量		14.5Ah	
Operating Voltage 工作电压		2.0~3.6V	/
Nominal Voltage 标称电压		3.2V	/
AC Internal Resistance 交流内阻		1.0mΩ≤IR<3.0mΩ	AC 1kHz, 30% SOC Standard Deviation≤0.2mΩ 标准差≤0.2mΩ
Cell Weight 电池重量		295±10g	contain package 包含外包装
Energy Density 能量密度		162Wh/kg 396Wh/L	/
Operating Temperature 工作温度	Charging Temperature 充电温度	0~60°C	No matter what charging and discharging mode the cell is in, once the cell surface temperature exceeds this range, the charging and discharging should be stopped. 无论电池处在何种充放电模式，一旦发现电池表面温度超过此范围即停止充放电
	Discharge Temperature 放电温度	-30~60°C	
Storage Temperature 存储温度		-20~45°C	3 months (3 个月)
		-10~25°C	6 months (6 个月)
Cycle Life 循环寿命	Standard Cycle 标准循环	≥2500 cycles	25±2°C, 0.5C/0.5C, 80% SOH
	Fast Charge Cycle 快充循环	≥3000 cycles	25±2°C, fast charge/1C discharge, 70% SOH 25±2°C, 快充充电方案/1C 放电, 70% SOH
Appearance 外观		Without break, scratch, distortion, contamination, leakage and so on 无破裂、划痕、变形、污迹、电解液泄露等	

该规格书为南京中比新能源科技有限公司企业标准，未经授权，不可翻印、传播。

This spec manual is the enterprise standard of NANJING CBAK ENERGY TECHNOLOGY COMPANY LIMITED, without authorization, any pirate or circulation is prohibited.

5.2. Charging Parameters 充电参数

Project 项目	Specification 规格		Condition 条件			
Standard Charging Mode 标准充电模式	0.5C CC/CV, cut off 3.6V/0.05C 0.5C 恒流恒压充电至 3.6V/0.05C 截止					
Standard Charging Current 标准充电电流	0.5C		/			
Max. Continuous Charging Current 最大持续充电电流	-10~0°C	0~10°C	10~20°C	20~45°C	45~50°C	50~60°C
	0.2C	0.33C	0.5C	1C	0.5C	0.2C
Standard End-of-charge Voltage 标准充电截止电压	3.6V		/			
Max. End-of-charge Voltage 最大充电截止电压	3.6V		No matter what charging mode the cell is in, once the cell voltage exceeds this range, the charging should be stopped. 无论电池处在何种充电模式，一旦发现电池电压超过此范围即停止充电			
Fast Charge Charging Time 快充充电时间	30min		30%~80% SOC, 25°C			
Optimum Charging Temperature Range 最佳充电温度范围	15~40°C		cell surface temperature 电池表面温度			
Max. Charging Temperature Range 最大允许充电温度范围	0~60°C		No matter what charging mode the cell is in, once the cell surface temperature exceeds this range, the charging should be stopped. 无论电池处在何种充电模式，一旦发现电池表面温度超过此范围即停止充电			

5.3. Discharge Parameters 放电参数

Project 项目	Specification 规格		Condition 条件			
Standard Discharge Mode 标准放电模式	0.5C CC, cut off 2.0V 0.5C 恒流放电至 2.0V 截止					
Standard Discharge Current 标准放电电流	0.5C		/			
Max. Continuous Discharge Current 最大持续放电电流	2C		15~45°C			
Max. Discharge Pulse Current 最大脉冲放电电流	6C (10s)		15~45°C			
End-of-discharge Voltage 放电截止电压	2.0V		/			
Max. Discharge Temperature Range 最大允许放电温度范围	-30~60°C		No matter what discharge mode the cell is in, once the cell surface temperature exceeds this range, the discharge should be stopped. 无论电池处在何种放电模式，一旦发现电池表面温度超过此范围即停止放电			

该规格书为南京中比新能源科技有限公司企业标准，未经授权，不可翻印、传播。

This spec manual is the enterprise standard of NANJING CBAK ENERGY TECHNOLOGY COMPANY LIMITED, without authorization, any pirate or circulation is prohibited.

5.4. Pulse Parameters 脉冲参数

5.4.1. Regen Pulse Current 脉冲充电电流

30s Regen Pulse Current Map/A-Cell Level 30s 脉冲充电电流 Map/A-电芯级别												
SOC Temp.	0%	5%	10%	20%	30%	40%	50%	60%	70%	80%	90%	95%
55°C	27.0	22.0	18.5	16.0	14.5	13.4	13.4	11.0	10.0	10.0	8.5	1.5
50°C	34.5	34.5	32.0	24.5	21.0	19.5	19.5	16.0	14.5	14.5	12.0	2.5
45°C	45.0	45.0	45.0	45.0	34.5	30.0	25.5	22.0	21.0	19.5	17.0	4.0
40°C	45.0	45.0	45.0	45.0	32.5	27.5	24.5	21.0	19.5	18.5	17.0	4.0
30°C	45.0	45.0	45.0	35.0	26.0	23.5	23.5	19.5	18.5	18.5	16.0	3.5
25°C	45.0	45.0	45.0	33.0	24.5	22.0	22.0	19.5	18.5	17.0	16.0	3.0
20°C	33.0	30.5	27.0	23.5	21.0	18.5	18.5	16.0	16.0	14.5	13.5	2.5
10°C	25.5	25.5	23.5	19.5	17.0	16.0	14.5	13.5	12.0	12.0	11.5	2.5
5°C	19.5	19.5	17.0	14.5	13.5	12.5	12.5	11.0	10.0	10.0	9.0	1.5
0°C	16.0	16.0	13.5	12.0	11.0	10.0	10.0	8.5	7.0	7.0	6.0	1.0
-10°C	6.5	6.5	6.0	5.5	4.5	4.0	4.0	3.5	3.0	2.5	2.0	0.5

5.4.2. Discharge Pulse Current 脉冲放电电流

30s Discharge Pulse Current Map/A-Cell Level 30s 脉冲放电电流 Map/A-电芯级别												
SOC Temp.	5%	10%	20%	30%	40%	50%	60%	70%	80%	90%	95%	100%
55°C	38.0	38.0	38.0	38.0	38.0	38.0	38.0	41.0	42.0	42.0	42.0	42.0
50°C	47.0	54.0	54.0	54.0	54.0	54.0	54.0	57.0	59.5	59.5	59.5	59.5
45°C	54.5	65.0	65.0	65.0	65.0	65.0	65.0	67.5	71.5	71.5	71.5	71.5
40°C	56.5	76.5	77.0	77.5	77.5	77.5	77.5	81.5	84.5	84.5	84.5	84.5
30°C	43.0	67.5	72.0	77.5	77.5	77.5	77.5	81.5	84.5	84.5	84.5	84.5
25°C	36.0	59.0	67.5	77.5	77.5	77.5	77.5	81.5	84.5	84.5	84.5	84.5
20°C	25.5	47.0	62.0	77.5	77.5	77.5	77.5	81.5	84.5	84.5	84.5	84.5
10°C	16.0	20.0	40.0	64.0	67.5	67.5	67.5	71.5	74.5	74.5	74.5	74.5
5°C	12.0	20.0	35.0	52.0	60.5	62.0	62.0	65.5	70.0	70.0	70.0	70.0
0°C	8.0	16.0	28.5	45.0	56.0	56.0	56.0	58.0	60.0	65.0	65.0	65.0
-10°C	6.0	12.0	20.5	36.0	38.5	40.0	45.0	45.0	48.0	48.0	52.5	52.5
-20°C	4.0	5.0	10.0	18.0	26.0	32.0	32.0	36.0	42.0	42.0	42.0	42.0

该规格书为南京中比新能源科技有限公司企业标准，未经授权，不可翻印、传播。

This spec manual is the enterprise standard of NANJING CBAK ENERGY TECHNOLOGY COMPANY LIMITED, without authorization, any pirate or circulation is prohibited.

6. Electrical Performance 电性能

Project 项目		Specification 规格	Condition 条件
Discharge Capacity Retention Rate at Different Temperatures 高低温性能	55°C/25°C	≥100%	55±2°C, 0.5C, cut off 2.0V
	0°C/25°C	≥85%	0±2°C, 0.5C, cut off 2.0V
	-10°C/25°C	≥75%	-10±2°C, 0.5C, cut off 1.8V
Discharge Capacity Retention Rate at Different Rates 倍率性能	1C/0.5C	≥98%	25±2°C, 1C
	2C/0.5C	≥98%	25±2°C, 2C
High Temperature Storage 高温存储	Charge Retention Rate 荷电保持率	≥95%	55±2°C, 7 days, 0.5C/0.5C
	Capacity Recovery Rate 容量恢复率	≥96%	
Normal Temperature Storage 常温存储	Charge Retention Rate 荷电保持率	≥96%	25±2°C, 28 days, 0.5C/0.5C
	Capacity Recovery Rate 容量恢复率	≥97%	

7. Safety Performance 安全性能

Project 项目	Test Method 测试方法	Inspection Standard 检验标准
Forced-discharge Test 过放电	详见 8.4.1 (GB 38031 8.1.2)	No fire, no explosion. 电池应不起火、不爆炸
Overcharge Test 过充电	详见 8.4.2 (GB 38031 8.1.3)	No fire, no explosion. 电池应不起火、不爆炸
Short-circuit Test 外部短路测试	详见 8.4.3 (GB 38031 8.1.4)	No fire, no explosion. 电池应不起火、不爆炸
Heating Test 加热测试	详见 8.4.4 (GB 38031 8.1.5)	No fire, no explosion. 电池应不起火、不爆炸
Temperature Test 温度循环测试	详见 8.4.5 (GB 38031 8.1.6)	No fire, no explosion. 电池应不起火、不爆炸
Crush Test 挤压测试	详见 8.4.6 (GB 38031 8.1.7)	No fire, no explosion. 电池应不起火、不爆炸
Drop Test 跌落测试	详见 8.4.7 (GB/T 31485 6.2.5)	No leakage, no fire, no explosion 电池应不漏液、不起火、不爆炸
Impact Test 重物冲击测试	详见 8.4.8 (UL 1642 14)	No fire, no explosion. 电池应不起火、不爆炸
Vibration Test 振动测试	详见 8.4.9 (UL 1642 16)	No leakage, no fire, no explosion 电池应不漏液、不起火、不爆炸
Low-pressure Test 低气压测试	详见 8.4.10 (UL1642 19)	No leakage, no fire, no explosion 电池应不漏液、不起火、不爆炸

该规格书为南京中比新能源科技有限公司企业标准，未经授权，不可翻印、传播。

This spec manual is the enterprise standard of NANJING CBAK ENERGY TECHNOLOGY COMPANY LIMITED, without authorization, any pirate or circulation is prohibited.

8. Test Method 测试方法

8.1. Standard Test Conditions 标准测试条件

Unless otherwise specified, all tests stated in this Specification are conducted at temp. $25\pm 2^{\circ}\text{C}$ and humidity 15-90%RH with fresh cell.

若无特别要求，此规格书上的产品测试条件均为温度： $25\pm 2^{\circ}\text{C}$ ，湿度：15-90%RH，新电池状态。

8.2. Standard Charge and Discharge Method 标准充放电制式

The "Standard Charge" means charging the Cell at a constant current of 0.5C until the voltage is 3.6V, then charged at a constant voltage of 3.6V until its current is less than 0.05C.

“标准充电制式”即以恒定电流 0.5C 充电至 3.6V，再以 3.6V 恒压充电至电流小于 0.05C。

The "Standard Discharge" means discharging the Cell at a constant current of 0.5C until the voltage is 2.0V.

“标准放电制式”即以恒定电流 0.5C 放电至 2.0V。

8.3. Electrical Performance Test 电性能测试

8.3.1 Discharge Capacity Test at Different Temperatures 高低温性能测试

A cell is charged in accordance with Standard Charge, and stored in a constant temperature box at the corresponding temperature for 4 hours, then discharged at a constant current of 0.5C to 2.0V ($T\geq 0^{\circ}\text{C}$)/1.8V ($T< 0^{\circ}\text{C}$).

电池按标准充电制式充电结束后，放入对应温度的恒温箱中恒温 4 小时，然后以 0.5C 恒流放电至 2.0V ($T\geq 0^{\circ}\text{C}$)/1.8V ($T< 0^{\circ}\text{C}$)。

8.3.2 Discharge Capacity Test at Different Rates 倍率性能测试

A cell is charged in accordance with Standard Charge, after that stored for 30min, then discharged to cut-off voltage at a constant current of 0.5C, after that, stored 30min; then the cell is charged and discharged as above except that at a discharged constant current of 1C; then the cell is charged and discharged as above except that at a discharged constant current of 2C.

电池按标准充电制式充电结束后搁置 30min，然后以 0.5C 恒流放电，放电结束后搁置 30min；这颗电池继续进行下一次充放电循环，需以 1C 进行恒流放电；继续进行下一次充放电循环，需以 2C 进行恒流放电。

8.3.3 High Temperature Storage Performance Test 高温存储性能测试

A cell is charged in accordance with Standard Charge, and stored in $55\pm 2^{\circ}\text{C}$ for 7d, after that stored for 5 hours at room temperature, then discharged in accordance with Standard Discharge. After that, stored for 30min, the cell is charged in accordance with Standard Charge, after that stored for 30min, then discharged in accordance with Standard Discharge.

电池按标准充电制式充电结束后，将电池在 $55\pm 2^{\circ}\text{C}$ 搁置 7 天，然后在室温下搁置 5 小时，再以标准放电制式放电，放电结束后搁置 30min；然后以标准充电制式充电结束后搁置 30min，再以标准放电制式放电。

8.3.4 Normal Temperature Storage Performance Test 常温存储性能测试

A cell is charged in accordance with Standard Charge, and stored in Standard Test Conditions for 28d, then discharged in accordance with Standard Discharge. After that stored for 30min, the cell is charged in accordance with Standard Charge, after that stored for 30min, then discharged in accordance with Standard Discharge.

电池按标准充电制式充电结束后，在标准测试条件下，将电池搁置 28 天，再以标准放电制式放电，放电结束后搁置 30min；此电池标准充电制式充电结束后，搁置 30min，然后以标准放电制式放电。

8.3.5 Standard Cycle Life Test 标准循环寿命测试

At Temp.: $25^{\circ}\text{C}\pm 2^{\circ}\text{C}$, a cell is charged at a constant current of 0.5C until the voltage is 3.6V, then charged at a constant voltage of 3.6V until its current is less than 0.05C, after that stored for 30min; then discharged at a constant current of 0.5C until the voltage is 2.0V, after that, stored 30min prior to next charge-discharge cycle. The charge and discharge cycle is carried out until the capacity retention rate is reduced to 80%.

温度 $25^{\circ}\text{C}\pm 2^{\circ}\text{C}$ ，电池以 0.5C 恒流充电至 3.6V，以 3.6V 恒压充电至电流小于 0.05C，结束后搁置 30min，然后以 0.5C 恒流放电至 2.0V，放电结束后搁置 30min，再进行下一次充放电循环，直到容量保持率降低至 80%。

8.3.6 Fast Charge Cycle Life Test 快充循环寿命测试

At Temp.: $25^{\circ}\text{C}\pm 2^{\circ}\text{C}$, a cell is charged by fast charge solution, after that stored for 30min; then discharged at a constant current of 1C until the voltage is 2.0V, after that, stored 30min prior to next charge-discharge cycle. The charge and discharge cycle is carried out until the capacity retention rate is reduced to 70%.

温度 $25^{\circ}\text{C}\pm 2^{\circ}\text{C}$ ，电池以快充充电方案进行充电，结束后搁置 30min，然后以 1C 恒流放电至 2.0V，放电结束后搁置 30min，再进行下一次充放电循环，直到容量保持率降低至 70%。

8.4. Safety Performance Test 安全性能测试

All below tests are carried out on the equipment with forced ventilation and explosion-proof device. Before test, all cells are charged in accordance with Standard Charge, and stored 1 hours prior to testing.

下述试验应在有强制排风条件及防爆措施的装置内进行，在试验前所有的电池都按标准充电制式充电，并搁置 1 小时后，再进行以下试验。

8.4.1 Forced-discharge Test 过放电 (GB 38031 8.1.2)

A cell is discharged at a constant current of 1C until the discharge time reaches 90min, then observed the cell for 1h.

电池以 1C 电流放电，直至放电时间到达 90min，观察 1 小时。

8.4.2 Overcharge Test 过充电 (GB 38031 8.1.3)

A cell is charged in accordance with Standard Charge, then charged the cell up to 4V or 115% SOC at CC of 1C, then observed the cell for 1h.

电池按标准充电制式充电结束后，对电池以 1C 恒流充电至 4V 或 115% SOC 后停止充电，观察 1 小时。

8.4.3 Short-circuit Test 外部短路测试 (GB 38031 8.1.4)

Short circuit the positive terminal and negative terminal of the cell externally for 10min (external line resistance $< 5\text{m}\Omega$), then observe for 1h.

将电池正极端子和负极端子经外部短路 10min（外部线路电阻 $< 5\text{m}\Omega$ ），观察 1 小时。

8.4.4 Heating Test 加热测试 (GB 38031 8.1.5)

A cell is heated in a circulating air oven. The temperature of the oven is raised at a rate of $5^{\circ}\text{C}\pm 2^{\circ}\text{C}$ per minute to a temperature of $130^{\circ}\text{C}\pm 2^{\circ}\text{C}$ and remain for 30min at that temperature before the test is discontinued, then observed the cell for 1h.

将电池放在电热鼓风干燥箱中，温度以 $5^{\circ}\text{C}\pm 2^{\circ}\text{C}/\text{min}$ 的速率由室温升至 $130^{\circ}\text{C}\pm 2^{\circ}\text{C}$ 并保持 30min 后停止加热，观察 1 小时。

8.4.5 Temperature Test 温度循环测试 (GB 38031 8.1.6)

A cell is charged in accordance with Standard Charge, heated the cell in an oven. In 60min, the temperature of the oven is dropped to the temperature of -40°C and remain for 90min at -40°C ; In 60min, the temperature of the oven is raised to the temperature of 25°C ; In 90min, the temperature of the oven is raised to the temperature of 85°C and remain for 110min at 85°C ; In 70min, the temperature of the oven is dropped to the temperature of 25°C ; Repeat this for 5 cycles, after that observed the cell for 1h.

电池按标准充电制式充电结束后，将电池放入温控箱内，在 60 分钟内，温控箱温度降至 -40°C ，并在 -40°C 温度下保持 90min；在 60 分钟内，温控箱温度升至 25°C ；在 90 分钟内，温控箱温度升至 85°C ，并在 85°C 温度下保持 110min；在 70 分钟内，温控箱温度降至 25°C ；重复以上步骤 5 次，观察 1h，目测电池外观。

8.4.6 Crush Test 挤压测试 (GB 38031 8.1.7)

A cell is to be placed on the crush surface, the axis is parallel to the crush surface, it is to be crushed between two flat surfaces. The pressure is gradually increased at an extrusion speed of $\leq 2\text{mm}/\text{s}$ until the voltage reaches 0V or the deformation reaches 15% or the squeezing force reaches 100kN or 1000 times the weight of the cell, keep the pressure for 10 minutes, and observe for 1 hour.

电池放在挤压设备的两个挤压面之间，圆柱电池芯轴平行于挤压平面，以 $\leq 2\text{mm}/\text{s}$ 的挤压速度，逐渐增加压力至电压达到 0V 或变形量达到 15% 或挤压力达到 100kN 或 1000 倍电池重量，保持压力 10min，观察 1 小时。

8.4.7 Drop Test 跌落测试 (GB/T 31485 6.2.5)

A cell is charged in accordance with Standard Charge, then dropped the cell from a height of 1.5m to the concrete ground with positive and negative terminals downward, then observed the cell for 1h.

电池按标准充电制式充电结束后，将电池样品的正负极端子向下由高度为 1.5m 的位置自由跌落到水泥地面上，观察 1 小时。

8.4.8 Impact Test 重物冲击测试 (UL 1642 14)

A cell is to be placed on the impact flat. A $\Phi 15.8\text{mm}$ bar is to be placed on the center of the cell. A 9.1kg weight is to be dropped from a height of 610mm onto the cell, the distortion is allowed.

将电池放在冲击台上，将一个 $\Phi 15.8\text{mm}$ 的钢柱置放电池中心，钢柱的纵轴平行于平面，让重量 9.1kg 重锤自 610mm 高度自由落下，冲击电池，电池允许发生变形。

8.4.9 Vibration Test 振动测试 (UL 1642 16)

A cell is charged in accordance with Standard Charge, then installed onto the vibration desk with clamps. Equipment parameters of frequency and amplitude are as follows (the frequency is varied at the rate of 1Hz/min between 10 and 55 hertz, and repeat vibration for 90-100min, amplitude: 0.16mm. The cell is tested in three mutually perpendicular directions). 电池按标准充电制式充电结束后，将电池用夹具安装在振动台的台面上，按下面的振动频率和对应的振幅调整好实验设备。X、Y、Z 三个方向每个方向上从 10~55Hz 循环扫频振动 90-100min，扫频速率为 1Hz/min，位移幅值 (单振幅): 0.16mm。

8.4.10 Low-pressure Test 低气压测试 (UL1642 19)

A cell is charged in accordance with Standard Charge, then stored it for 6 hours at an absolute pressure of 11.6kPa, then check cell's appearance.

电池按标准充电制式充电结束后，将电池放入在绝对压力为 11.6kPa 下搁置 6 小时，目测电池外观。

9. Packaging and Shipment 包装出货

9.1. Packaging 包装

Each box is loaded with 40pcs batteries, and the RoHS logo and the finished battery identity card are posted on the outside of the box, as shown in Figure B.

每箱装入 40pcs 电池，箱体外部张贴 RoHS 标识及成品电池标识卡，如图 B 所示。

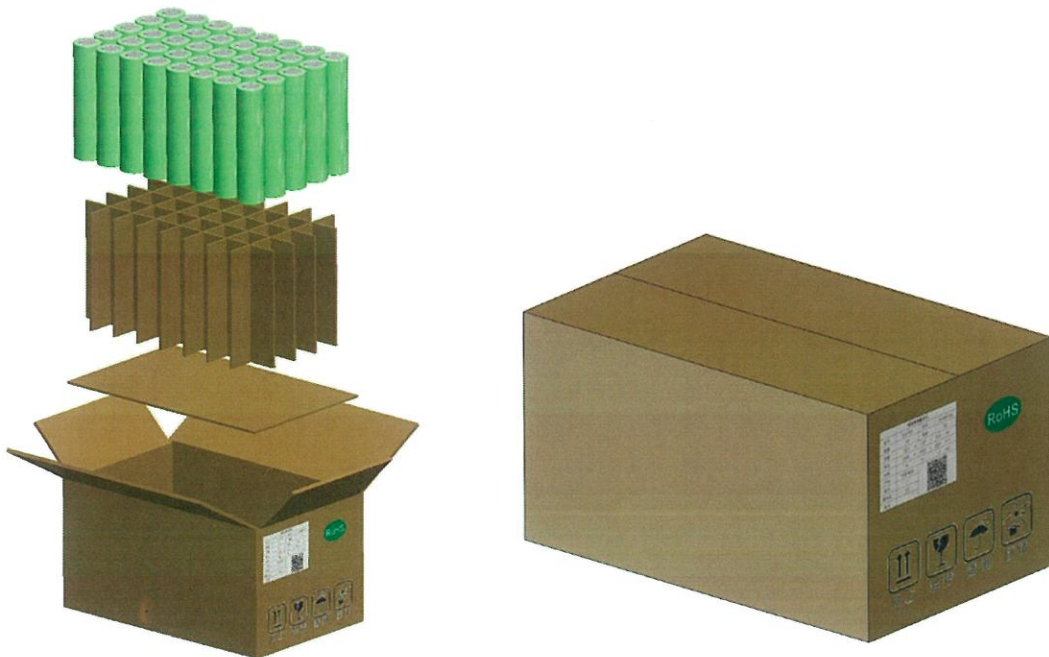

Figure B (图 B)

The cardboard has 15 boxes per layer, stacking ≤ 5 layers, as shown in Figure C.

卡板每层 15 个箱子，堆叠 ≤ 5 层，如图 C 所示。

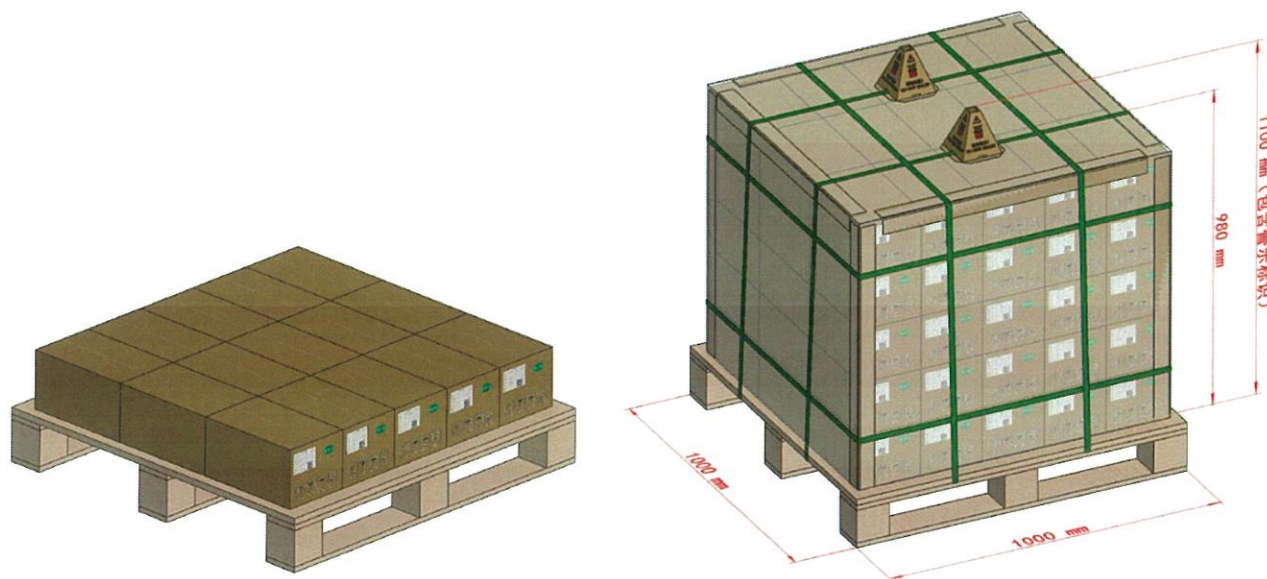

Figure C (图 C)

9.2. Shipment 出货

The Cell shall be shipped in 20-30% state-of-charge (SOC) or in accordance with customers' requirement. The remaining capacity of the cell after shipment and before charging depends on the storage time and conditions.

单体电池按 20-30% 的充电容量或客户要求出货，电池出货后充电前的剩余容量取决于储存时间和条件。

10. Warranty 质量保证

The Warranty period of cell is made according to business contract, However, even though the problem occurs within this period, NANJING CBAK ENERGY TECHNOLOGY COMPANY LIMITED won't replace a new cell for free as long as the problem is not due to the failure of NANJING CBAK ENERGY TECHNOLOGY COMPANY LIMITED manufacturing process or is due to customer's abuse or misuse.

自出货之日起，电池的保质期限依合同而定。但是，在此期限内，如果不是南京中比新能源科技有限公司的制程原因而是客户的误用造成的电池质量问题，南京中比新能源科技有限公司不承诺免费更换。

NANJING CBAK ENERGY TECHNOLOGY COMPANY LIMITED will not be responsible for trouble occurred by handling outside of the precautions in instructions.

南京中比新能源科技有限公司对违反安全守则操作所产生的问题不承担任何责任。

NANJING CBAK ENERGY TECHNOLOGY COMPANY LIMITED will not be responsible for trouble occurred by matching electric circuit, cell pack and charger.

南京中比新能源科技有限公司对与电路、电池组、充电器搭配使用所产生的问题不承担任何责任。

NANJING CBAK ENERGY TECHNOLOGY COMPANY LIMITED will be exempt from warrantee any defect cells during assembling after acceptance.

出货后客户在电池组装过程中产生的不良电池不在南京中比新能源科技有限公司质量保证的范围之列。

11. Precautions and Safety Instructions 安全守则

Lithium-Ion rechargeable batteries subject to abusive conditions can cause damage to the cell and/or personal injury. Please read and observe the standard cell precautions below before using utilization.

滥用锂离子充电电池可能会造成电池损害或人身伤害，在使用以前，请仔细阅读以下的安全守则：

Note 1. The customer is required to contact NANJING CBAK ENERGY TECHNOLOGY COMPANY LIMITED in advance, if and when the customer needs other applications or operating conditions than those described in this document.

注释 1: 如果客户需要将电池在该文件之外条件下操作或应用，请先咨询南京中比新能源科技有限公司相关事宜。

Note 2. NANJING CBAK ENERGY TECHNOLOGY COMPANY LIMITED will take no responsibility for any accident when the cell is used under other conditions than those described in this Document.

注释 2: 在该文件说明的条件之外使用该电池而产生的事故，南京中比新能源科技有限公司不承担任何责任。

11.1. Standard cell Precautions 电池防范措施

- a) Do not throw the Battery cell into fire or heat it.
不要将电池投入火中或加热。
- b) Do not short circuit, over-charge or over-discharge the cell.
不要将电池短路，过充或过放。
- c) Do not subject the cell to strong mechanical shocks.
不要使电池承受过重的机械冲击。
- d) Do not immerse the cell in water or sea water, or get it wet.
不要将电池浸入海水或水中，或者使其吸湿。
- e) Do not reverse the polarity of the cell for any reason.
不要颠倒电池的正负极。
- f) Do not disassemble or modify the cell.
不要拆卸或修整电池。
- g) Do not handle or store with metallic like necklaces, coins or hairpins, etc.
不要和项链，硬币或发夹等金属物品放置在一起。
- h) Do not use the cell with conspicuous damage or deformation.
不要使电池受到明显的损害或变形。
- i) Do not connect cell to the plug socket or car-cigarette-plug.
不要将电池与插座连接。
- j) Do not touch a leaked cell directly.
不要直接接触泄漏的电池。
- k) Do not use Lithium-ion cell in mixture.
不要将锂离子电池混合使用。
- l) Do not use or leave the cell under the blazing sun (or in heated car by sunshine).
不要将电池放置在太阳光直射的地方。
- m) Keep cell away from children.
将电池放置在远离儿童的地方。
- n) Do not drive a nail into the cell, strike it by hammer or tread it.
不要针刺，锤打或践踏电池。
- o) Do not give cell impact or fling it.
不要撞击或投掷电池。
- p) Do not put Battery Cell into microwave oven or high pressure container.
不要将电池放入微波炉或高压容器中。

该规格书为南京中比新能源科技有限公司企业标准，未经授权，不可翻印、传播。

This spec manual is the enterprise standard of NANJING CBAK ENERGY TECHNOLOGY COMPANY LIMITED, without authorization, any pirate or circulation is prohibited.

11.2. Cell Operation Instructions 电池使用说明

11.2.1. Charging 充电

a) When the Battery Cell is charged, the specified charge method and current described in this PS-Documents should apply. If charge current exceeds the upper limit of the specified range, characteristics and safety of the Battery Cell could be deteriorated, or it may cause heat, explosion and fire.

应遵守本规格书的充电方式。如果超过电流上限，电池的安全性将不能被保证，会引起发热，爆炸，起火。

b) Charge voltage should not exceed 3.8V.

充电电压不能超过 3.8V。

c) Charge the cell in a temperature range of 0°C to 60°C.

电池充电温度范围为 0°C~60°C。

d) Use a constant current, constant voltage (CC/CV) lithium-ion (Li⁺) cell charge controller.

使用恒流恒压锂离子电池充电器。

11.2.2. Discharging 放电

a) The discharge current should not exceed the designated current described in this PS-Documents. If the discharge current exceeds the specified value, discharge capacity could be extremely deteriorated or the Cell could be heated.

放电电流不能超过本规格书的规定值，如果电流超过了规定值，电池容量将被破坏或者电池会出现发热情况。

b) For maximum performance, discharge the cell in a temperature range of 15°C to 40°C.

为了达到较好的性能，电池的放电温度范围为 15°C~40°C。

11.2.3. Storage Recommendations 储存建议

a) Do not store the Battery Cell together with combustibles.

不要将电池和易燃物一起存放。

b) The cell shall be stored in a clean, dry and ventilated environment. In case of long period storage (more than 3 months), the storage temperature of the cell should be within the range of -10 to 25°C. It is recommended to charge/discharge once every 3 months, and the SOC remains between 25-75%.

电池应存储在相对湿度≤75%RH 和不含腐蚀性气体的清洁、干燥、通风的环境中。如果要长时间存放（超过 3 个月），电池存储温度应在-10~25°C范围内，建议每隔 3 个月充放电一次，SOC 保持在 25-75%之间。

c) No press on the cell.

不要让电池承受任何压力。

12. Consultation 技术咨询

As to the obscurity, contact the following.

Address: No. 5, Cangxi Road, Gaochun District, Nanjing

Tel No.: +86-025-57878089

如有疑问，请按以下方式咨询

厂址：南京市高淳区沧溪路 5 号

电话号码：+86-025-57878089

<http://www.cbak.com.cn>

13. Requirement for Safety Assurance 安全保证要求

For the sake of safety, please consult NANJING CBAK ENERGY TECHNOLOGY COMPANY LIMITED for equipment design, lithium-ion cell system protection circuit or high current, fast charging and other special applications.

为了安全起见，如有设备设计，锂离子电池系统保护电路或高电流，快速充电及其它方面的特殊应用，请先咨询南京中比新能源科技有限公司相关事宜。